



## INSTALLATION INSTRUCTIONS FOR CLASS 2, 12 VOLTS ELECTRONIC LED POWER SUPPLY INDOOR AND OUTDOOR DRY AND DAMP



### ⚠ WARNING

To avoid electrical shock or fire:  
Disconnect power at service panel prior to installation, troubleshooting or maintenance.  
Always follow NEC and local electrical codes. Properly ground power supply and fixture.  
Do not connect output of power supplies in series or parallel to double up voltage or current.

Thank you for purchasing Allanson's LED Power Supply. Should you have questions or concerns please do not hesitate to contact us. Please read all installation instructions before installing this system.

### SPECIFICATIONS

Part #	ACV3125-120-277V
Input Voltage	120-277V
Input Frequency	50/60Hz
Input Current @ Rated Load	1.70A @ 120V
Input Current @ Rated Load	0.75A @ 277V
Power Factor	HPF>95%
Output Voltage	12Vdc +/- 3%
Output Current 1	5A
Output Current 2	5A
Output Current 3	5A
Size (LxWxH)	16.70"x1.69"x1.18"
Max Ambient Operating Temperature	-40°C to 55°C
Certification	UL / CSA

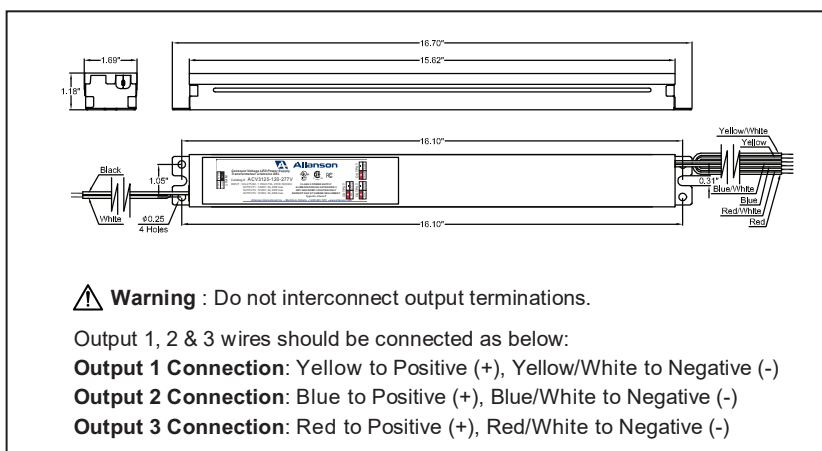

Illustration 1



### INSTALLATION AND OPERATION

- Firmly secure the case to the application with proper size screws.
- LED power supply and all surrounding metal should be bonded to ground. All metal parts of the individual channel letter and the sign frame must be grounded to the point of power connection in accordance with local electrical codes and other ordinances.
- Wire the power supply to a standard three-wire grounded power source.
- Use output leads #18 AWG or heavier to wire the LED modules. For best results, keep the leads as short as possible. The recommended length between the output of the power supply and the first LED module should be less or equal to 9 feet using #18 AWG (expected 5% voltage drop).
- If you need to extend the distance between the power supply to the LED modules, please increase the wire gauge to minimize the voltage drop to the modules. A reduction in voltage to the modules will cause a proportional reduction in light output. The table attached is only a guide.

Distance to Power Supply	Stranded Copper Wire Gauge	Expected Voltage Drop
13 ft.	#16 AWG	5%
20 ft.	#14 AWG	5%
30 ft.	#12 AWG	5%

- Firmly secure the LED modules to a flat metal surface.
- Attach the positive lead wire of the LED module to the positive (+) terminal of the power supply. Attach the negative terminal of the LED module to the negative (-) terminal of the power supply.
- Do not overload the unit. Follow each system's specification for correct loading.
- The power supply and the LED modules generate heat during normal operation and it is necessary to allow heat to dissipate. It is recommended they are mounted with as much of their surface in direct contact with other metal surfaces as possible. Letters should be well ventilated.
- Power supplies may be joined together on the primary side with a junction box in a wide array of configurations. All connections must be performed in accordance with NEC and local electrical codes.
- For installation in dry and damp locations, the junction box MUST BE a UL Listed or CSA Certified junction box.



## Troubleshooting

No Light output	Make sure power at breaker is <b>ON</b> . Make sure connections are correct between line and power supply, and between power supply and LED chain. Check output of the power supply using a voltmeter. The output should be 12VDC. Have a licensed electrician check the power at the input of the power supply. Short circuit at the output will shut down the unit.
Sections of LED module does not light up	Check connections and polarity between power supply and LED module, connectors and polarity between LED modules.
One LED Module does not light up	If all other LED modules are working except one, replace this one module. The modules are in parallel and will not cause other modules to fail if one fails.
Not enough light output Light turns off and on periodically	Make sure the LED load does not exceed the output rating of the LED power supply. Fasten any loose modules or arrays.
Shadows	Tape any wires down that are interfering with the LED modules. Fasten any loose modules.
Unit attempts to restart	In fault condition mode, the power supply will attempt to restart periodically and resume normal operation after fault condition is removed.